

OWNER'S MANUAL

Model No: DA0504KMC-1N (NATURAL)

Model No: DA0504KMC-1W (WHITE)

CAUTION:
Carefully Read Instructions and
Procedures for Safe Operation
ADULT ASSEMBLY REQUIRED

Date of purchase:

____ / ____ / ____

3 IN 1 CONVERTIBLE CRIB



Receipt of Purchase:

Attach Here:



NEED HELP!
CALL US FOR ASSISTANCE
1-800-295-1980
DO NOT RETURN PRODUCT TO STORE
E-MAIL: DAS@DOREL.COM

CUSTOMER SERVICE

If you are missing parts or have any questions about this product, contact our customer service representative first!



CALL 1-800-295-1980

You can also order parts by writing to the address listed below. Please include the product model number, color and a detailed description of the part.

**Customer Service Department No. 413
12345 Albert-Hudon Boulevard, Suite 100
Montreal, Quebec
Canada H1G 3L1
E-MAIL: das@dorel.com**



WARNING

- * Failure to follow these warnings and assembly instructions could result in serious injury or death.
- * Read all instructions before assembling crib. **KEEP INSTRUCTIONS FOR FUTURE USE.**
- * Before each usage or assembly, inspect crib for damaged hardware, loose joints, missing parts or sharp edges, **DO NOT** use crib if any parts are missing or broken. Ask your dealer or write to our customer service representative (address & phone number shown above) for replacement parts and instructional literature if needed. **DO NOT** substitute parts.
- * Infants can suffocate on soft bedding. Never add a pillow, comforter or padding.
- * When child is able to climb out or reaches the height of 35 inches (90 cm), the crib shall no longer be used.
- * To reduce the risk of SIDS, pediatricians recommend healthy infants be placed on their backs to sleep, unless otherwise advised by your physician.
- * **DO NOT** place crib near window where cords from blinds or drapes may strangle a child.
- * Strings can cause strangulation! **DO NOT** place crib with a string around a child's neck, such as hood strings or pacifier cords. **DO NOT** suspend strings over a crib or attach strings to toys.
- * To help prevent strangulation tighten all fasteners. A child can trap parts of the body or clothing on loose fasteners.
- * If refinishing, use a non-toxic finish specified for children's products.
- * When child is able to pull to standing position, set mattress to lowest position and remove bumper pads, large toys and other objects that could serve as steps for climbing out.
- * Never use plastic shipping bags or other plastic film as mattress covers because they can cause suffocation.
- * **DO NOT** use a water mattress with this crib.
- * Replace teething rail if damaged or loose (if teething rail is provided for this model).
- * **CAUTION: ANY MATTRESS USED IN THIS CRIB MUST BE AT LEAST 27-1/4 INCHES BY 51-5/8 INCHES (69CM BY 131CM) WITH A MINIMUM THICKNESS OF 4 INCHES (10CM) BUT NOT EXCEEDING 6 INCHES (15CM).**
- * Infants can suffocate in gaps between crib sides and a mattress that is too small.



WARNING ENTRAPMENT / STRANGULATION HAZARD:

- * Infants have died in toddler beds from entrapment and strangulation
- * **NEVER** use bed with children under 15 months.
- * **NEVER** place bed near windows where cords from blinds or drapes may strangle a child.
- * The **TODDLER BED** or **DAY BED** is not intended for children under 15 months of age or over 50 pounds (22.7kg).
- * If guardrails are used as the mattress containment means, guardrail(s) provided must be used to avoid the formation of a gap between the mattress and the bed that could cause an entrapment (when product is used as a **TODDLER BED** or **DAY BED**).
- * **DO NOT** place **DAY BED** or **TODDLER BED** near windows where cords from blinds or drapes may strangle a child.
- * **DO NOT** place items with a string, cord, or ribbon around a child's neck, such as hood strings or pacifier cords.
- * **DO NOT** suspend strings over a **TODDLER BED** or **DAY BED** for any reason.

NOTES

- * Ensure all parts and components are present before beginning assembly.
- * Assemble on soft, smooth surface to prevent damage to product finish.
- * Phillips head screw driver is not included.
- * DO NOT use power tools.
- * CAUTION: Adult assembly required.
- * Assembly will require two people.



WARNING: Should this product become damaged, and/or components are broken or missing, DO NOT USE.

CARE AND CLEANING

Dust regularly with a soft, lint-free cloth to prevent soil build-up. A damp cloth may be used occasionally to clean surface. Dry immediately. Do not use any abrasives that may damage finish. Excessive exposure to sunlight and extreme changes in temperature and moisture can damage wood furniture.

If the crib is to be stored, store in cool dry place and carefully package all original hardware to protect from loss.







MAINTENANCE

Check bolts/screws periodically and tighten them if necessary.

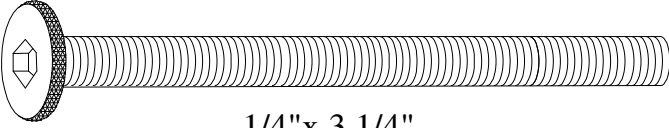
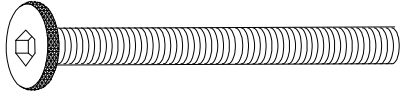
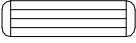
DOREL ASIA LIMITED WARRANTY

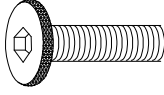

Dorel Asia warrants its product to be free from defects in material and workmanship and agrees to remedy any such defect. This warranty covers 1 year from the date of original purchase. This warranty is valid only upon presentation of proof of purchase. This is solely limited to the repair or replacement of defective furniture components and no assembly labor is included. This warranty does not apply to any product which has been improperly assembled, subjected to misuse or abuse or which has been altered or repaired in any way. This warranty gives you specific legal rights and you may also have other rights which vary from State to State.

HARDWARE LIST

<p>A</p>  <p>1/4"x 3 1/4"</p>		<p>B</p>  <p>1/4"x 1 3/4"</p>
<p>ALLENHEAD BOLT 8PCS</p>		<p>ALLENHEAD K-D BOLT 6PCS</p>
<p>C</p> 	<p>D</p> 	<p>E</p> 
<p>ALLENHEAD BOLT 4PCS</p>	<p>ALLEN KEY 1PC</p>	<p>ALLENHEAD K-D BOLT 2PCS</p>
<p>F</p> 	<p>G</p>  <p>∅ 6 mm x 3/4"</p>	<p>H</p>  <p>1/8"x 1 1/4"</p>
<p>MACHINE SCREWS 2PCS</p>	<p>MATTRESS SUPPORT BOLT 16PCS</p>	<p>GATE PIN 2PCS</p>

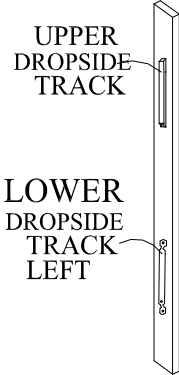
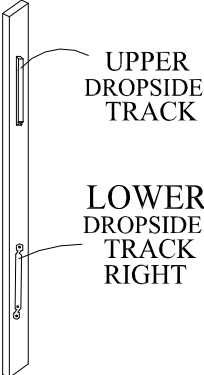
PARTS LIST

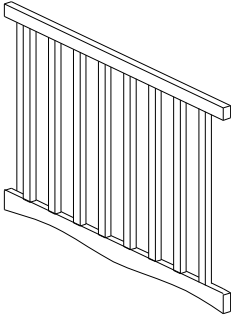
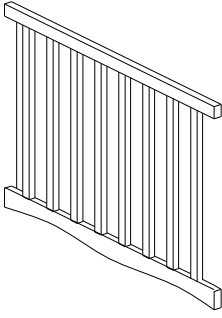
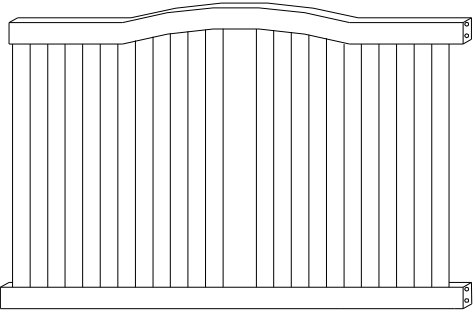
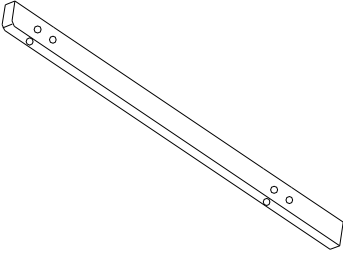
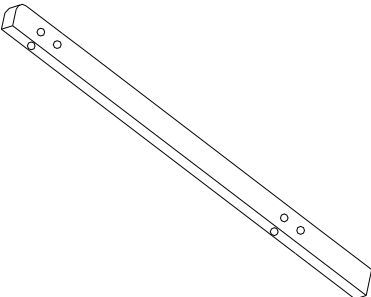
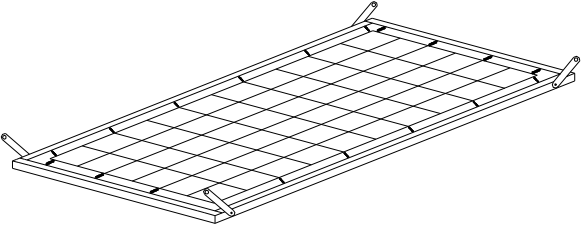
<p>I</p>  <p>UPPER DROPSIDE TRACK</p> <p>LOWER DROPSIDE TRACK LEFT</p>	<p>J</p>  <p>UPPER DROPSIDE TRACK</p> <p>LOWER DROPSIDE TRACK RIGHT</p>
<p>LEFT FRONT LEG 1PC</p>	<p>RIGHT FRONT LEG 1PC</p>

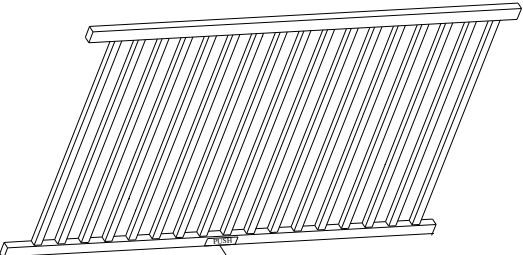
K		L	
LEFT SIDE FRAMES 1PC		RIGHT SIDE FRAMES 1PC	
M		M1	
HEADBOARD 1PC		LEFT BACK LEG 1PC	
M2		N	
RIGHT BACK LEG 1PC		MATTRESS SUPPORT 1PC	
O		P	 PUSH
DAY BED RAIL 1PC		DROP SIDE 1PC	

ASSEMBLY DIRECTIONS FOR "CRIB"

NOTE:PLEASE MAKE SURE THE TEETHING RAIL IS ON TOP OF THE DROP SIDE

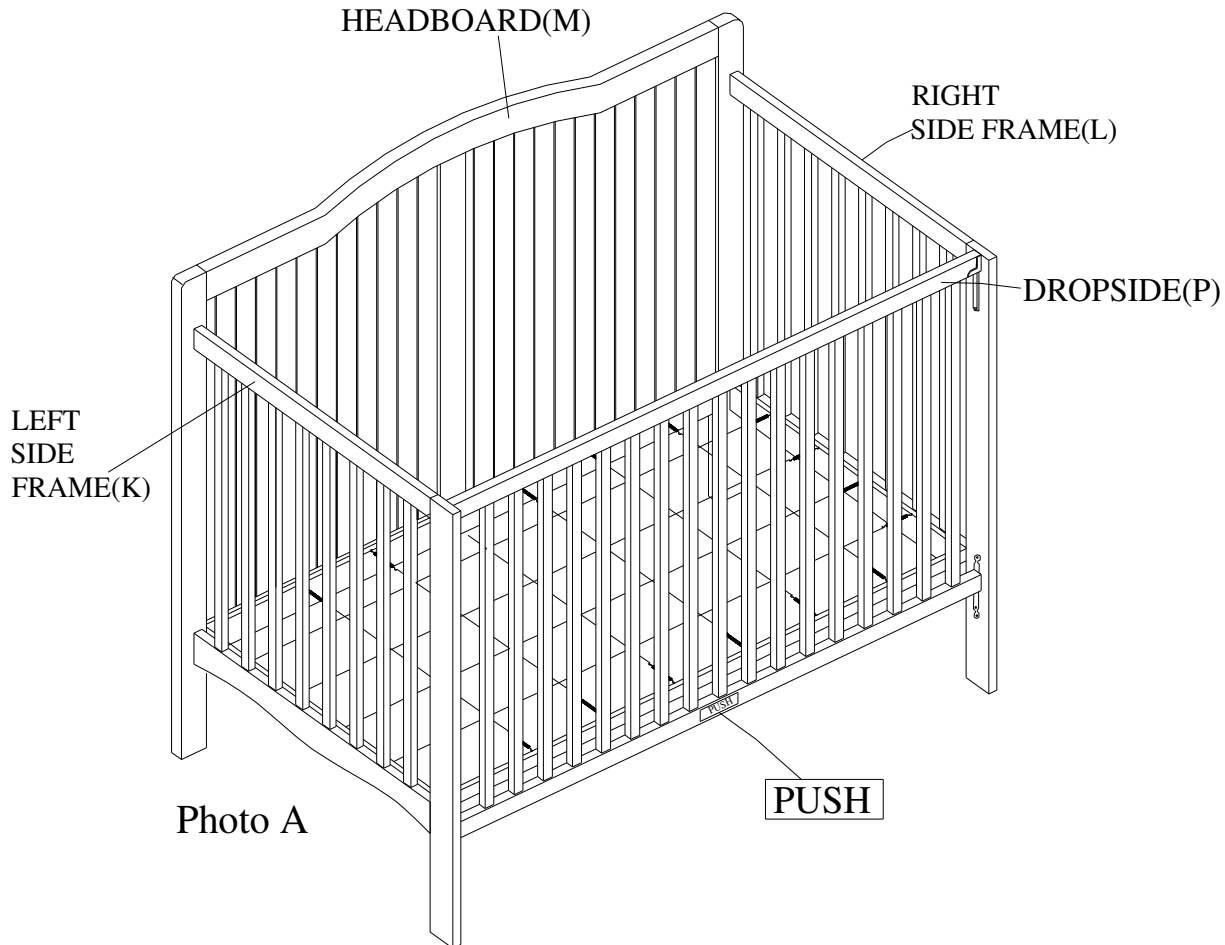

CRIB ASSEMBLY INSTRUCTIONS

NOTE:WHEN INSERTING SCREWS .TURN CLOCKWISE UNTIL TIGHT , THEN LOOSEN 1/2-3/4 OF A TURN,AFTER CRIB COMPLETELY ASSEMBLED, RETURN TO EACH SCREW AND TIGHTEN,USE WAX OR SOAP ON ALL SCREWS TO FACILITATE ASSEMBLY .

HEADBOARD ASSEMBLY

STEP:1

ATTACH LEFT AND RIGHT BACK LEGS (PARTS M1&M2) TO HEADBOARD (PART M) ,USING JOINT CONNECTING BOLTS(PART A) AND WOOD DOWEL (PART C). USE ALLEN WRENCH (PART D) TO TIGHTEN THE BOLTS (PART A).

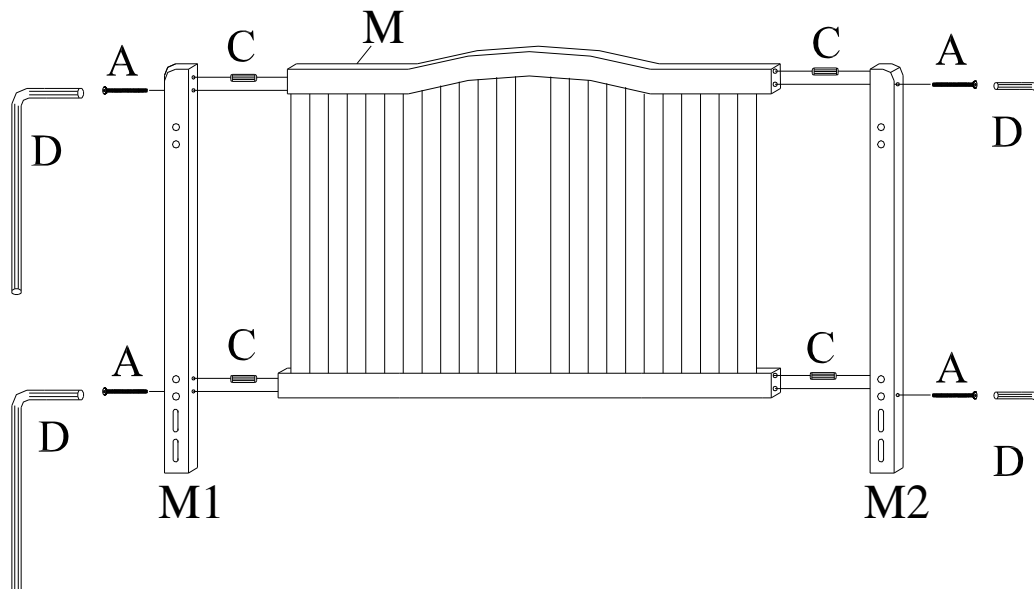

STEP:2

ATTACH RIGHT FRONT LEG (PART J)TO RIGHT SIDE FRAME (PART L)USING 2 JOINT CONNECTING BOLTS(PART A) USE ALLEN WRENCH TO TIGHTEN THE BOLTS. REPEAT THIS STEP WITH LEFT FRONT LEG (PART I) AND LEFT SIDE FRAME (PART K) .

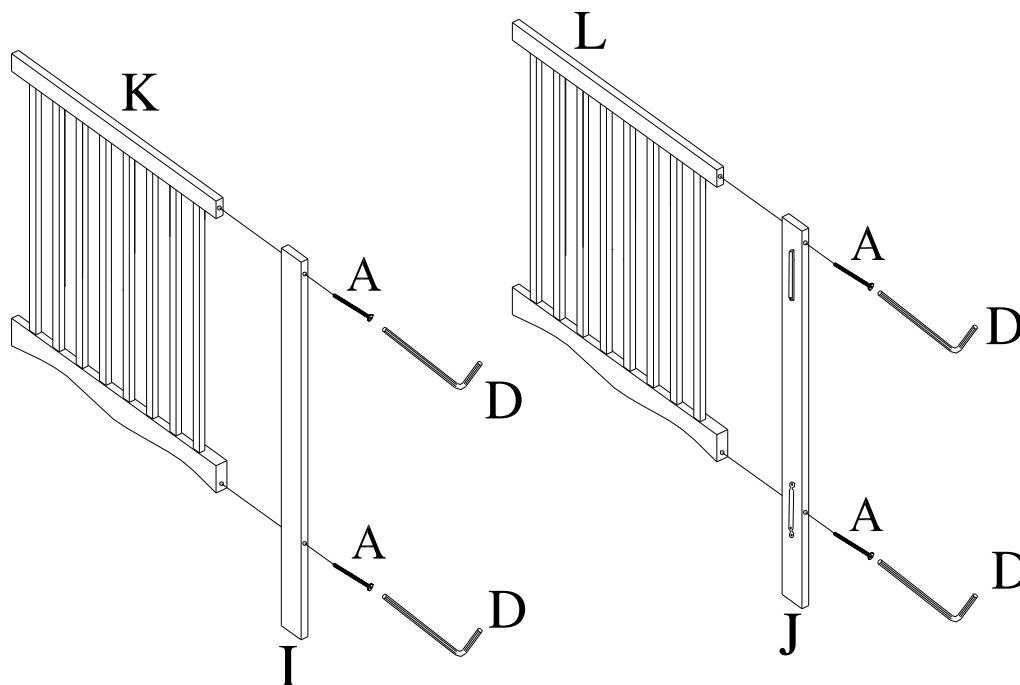

STEP:3

ATTACH LEFT SIDE FRAME ASSEMBLY TO THE HEADBOARD ASSEMBLY USING 2 JOINT CONNECTING BOLTS (PART B). REPEAT THIS STEP WITH RIGHT SIDE FRAME ASSEMBLY .

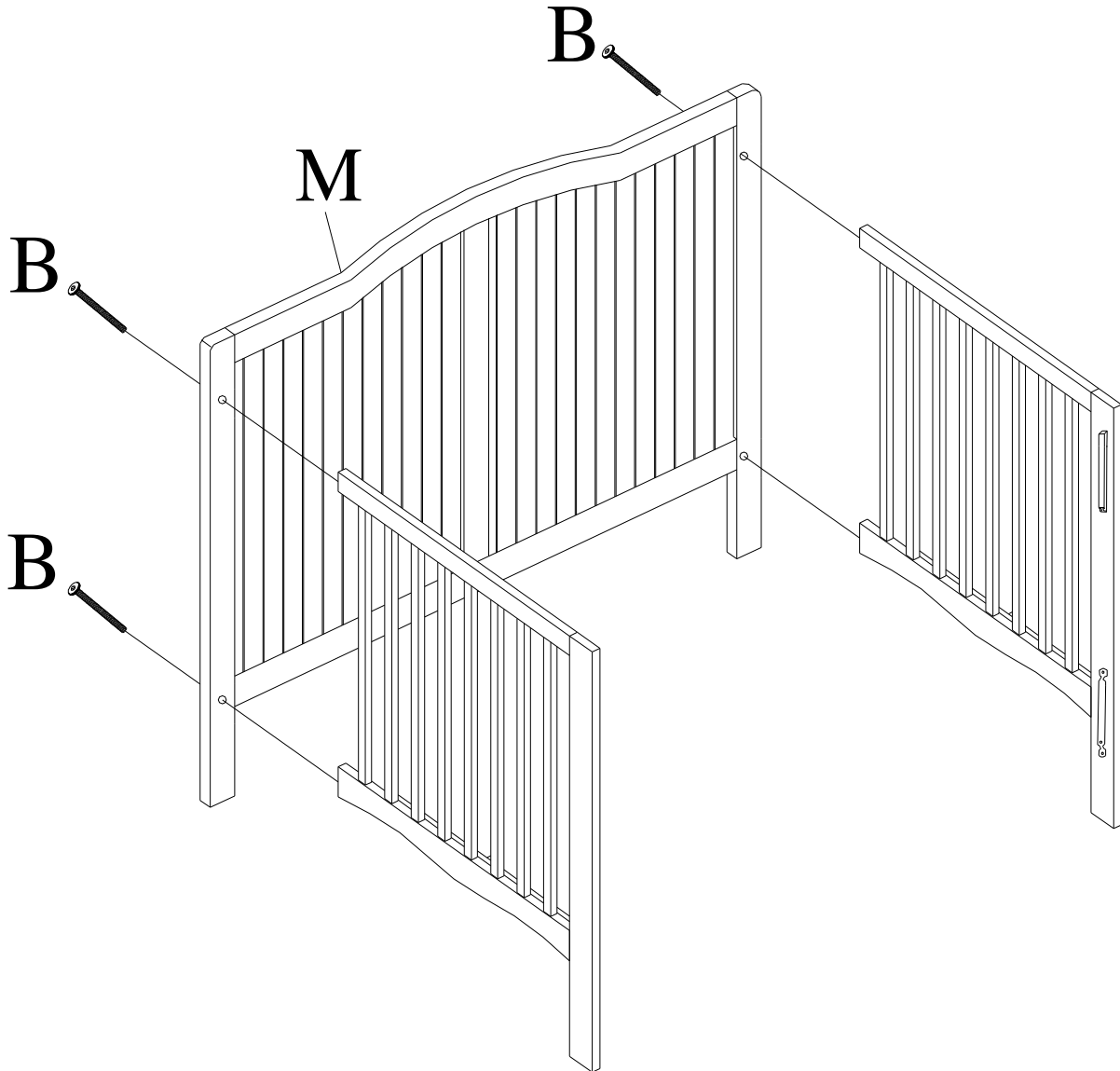

STEP:4

ATTACH MATTRESS SUPPORT(PART N)
TO THE LEGS USING 4 MATTRESS
SUPPORT BOLTS(PART G).A WRENCH
HAS BEEN PROVIDED TO SECURE ALL
4 MATTRESS SUPPORT BOLTS
(PART G).

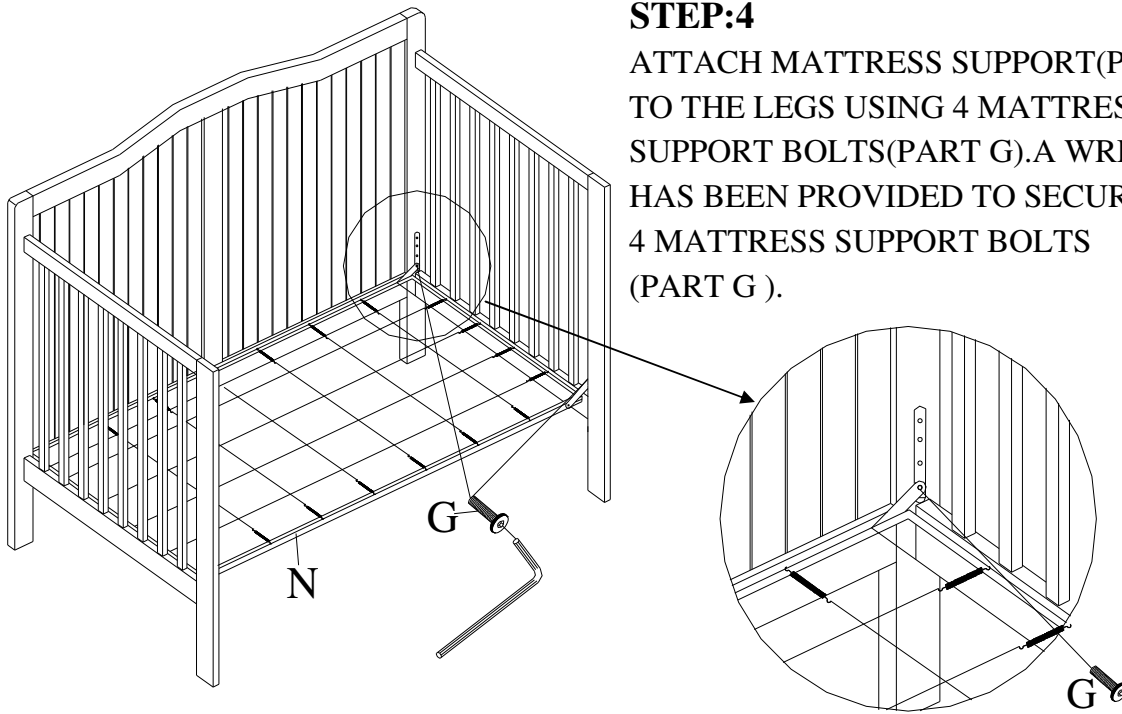

NOTE:

THE MATTRESS SUPPORT TABS SHOULD ALWAYS BE ABOVE THE MATTRESS
SUPPORT WHEN ASSEMBLED (REFER TO DETAIL.1).

ENSURE THE FLAT SIDE OF THE MATTRESS SUPPORT (N) IS FACING
UP. THE MATTRESS MUST SIT ON THE MATTRESS SUPPORT AND NOT
INSIDE THE RECESSED EDGES.

DETAIL.1

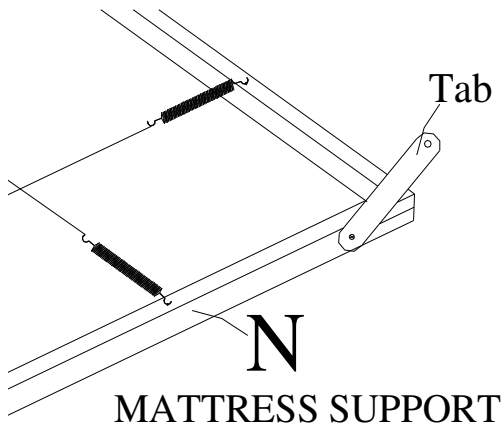

DETAIL.2

NOTE:PLEASE ENSURE THAT THE REST OF
HEIGHT ADJUSTMENT HOLES ARE FILLED WITH
SCREWS (G) AFTER THE MATTRESS SUPPORT
HAS BEEN MOVED TO THE SELECTED LEVEL.
MAKE SURE THAT THESE SCREWS ARE
TIGHTLY SECURED

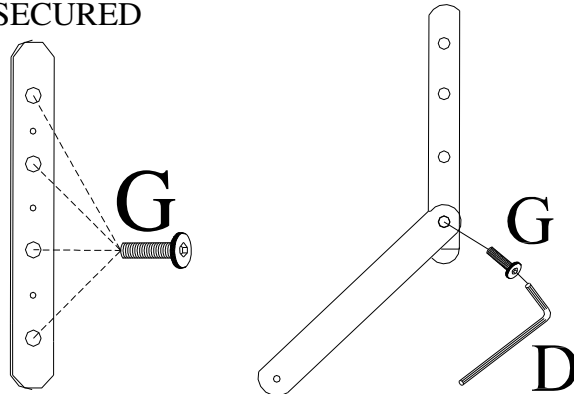

STEP:5

ALIGN AND SLIDE DROPSIDE(PART P)FROM THE BOTTOM ONTO THE DROPSIDE UPPER AND LOWER TRACKS ON THE LEFT AND RIGHT FRONT LEGS MAKE SURE THE RELEASE LATCH ON THE LOWER GUIDES (PART P)IS TO THE OUTSIDE OF THE LOWER DROPSIDE TRACKS (PULL TOWARDS YOU) RAISE DROPSIDE(PART P)UNTIL IT LOCKS INTO PLACE .CAUTION ,DO NOT FORCE THE DROPSIDE AS YOU MAY BREAK THE LOCKS,GUIDES,OR TRACKS .ATTACH RUBBER WASHER BEFORE OPERATING DROPSIDE.

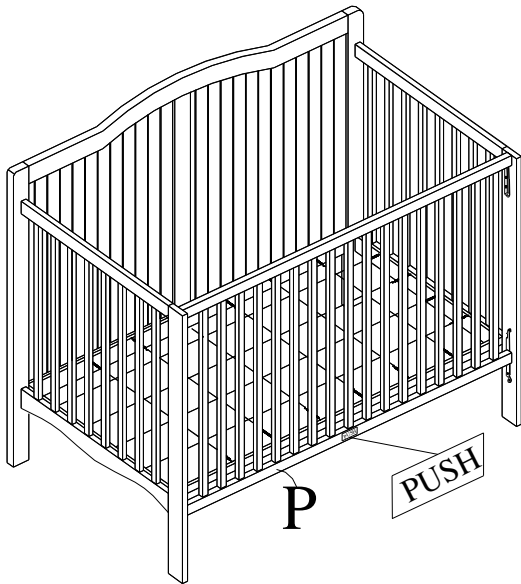

OPERATING INTRUCTIONS FOR DROP SIDE.

STAND AT THE MIDDLE OF THE DROPSIDE AND HOLD THE TOP RAIL WITH ONE HAND. RAISE THE DROPSIDE SLIGHTLY TO ENABLE YOU TO RELEASE THE LATCH BY PUSHING ON THE DROPSIDE LOWER RAIL WITH YOUR KNEE .THE DROPSIDE WILL NOW LOWER. RAISE THE DROP SIDE AND IT WILL AUTOMATICALLY LOCK AT THE UPPER POSITION. ALWAYS MAKE SURE DROP SIDE IS PROPERLY SECURED.

NOTE:WHEN ASSMBLING THE DROPSIDE MAKE SURE THE TEETHING RAIL IS ON TOP

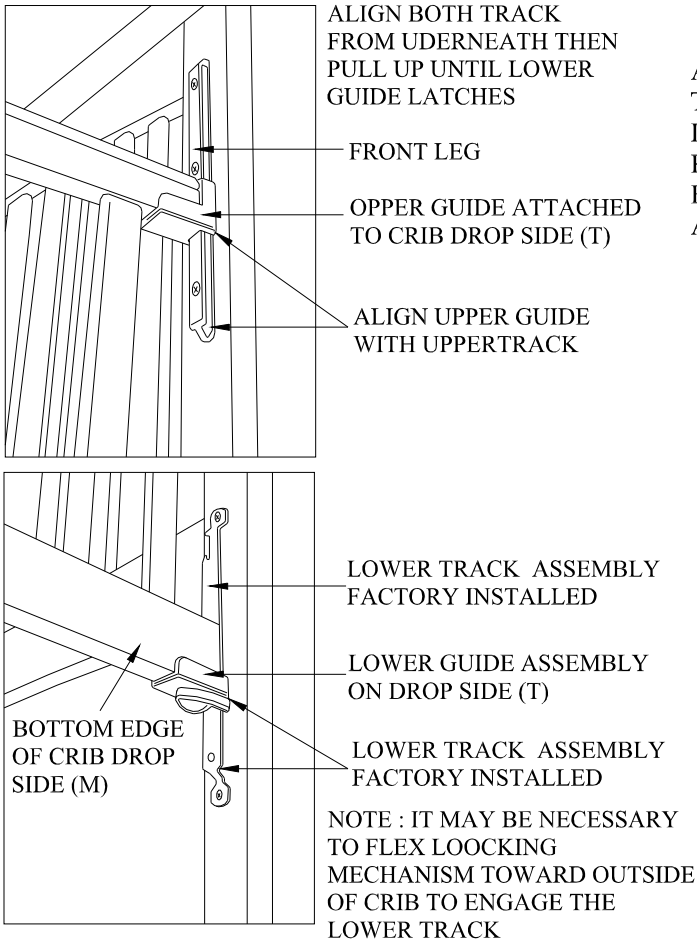

AFTER DROP SIDE (P) IS INSTALLED ON THE TRACK AND IS LATCHED IN THE UP POSITION. INSERT THE MACHINE SCREWS (F) INTO THE RUBBER WASHERS (E) AND THREAD INTO THE EMPTY HOLES NEAR BOTTOM ON LOWER TRACK ASSEMBLY (FACTORY MOUNTED)

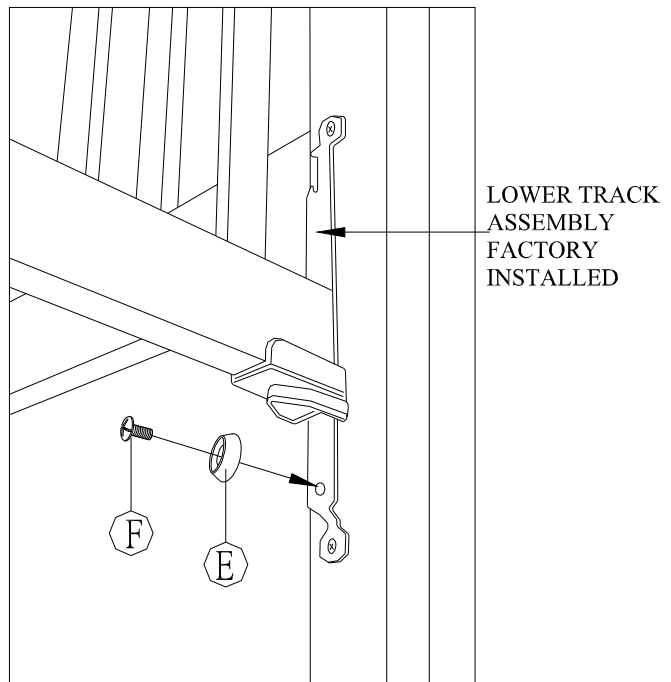

DAY BED ASSEMBLY INSTRUCTIONS (PHOTO B)

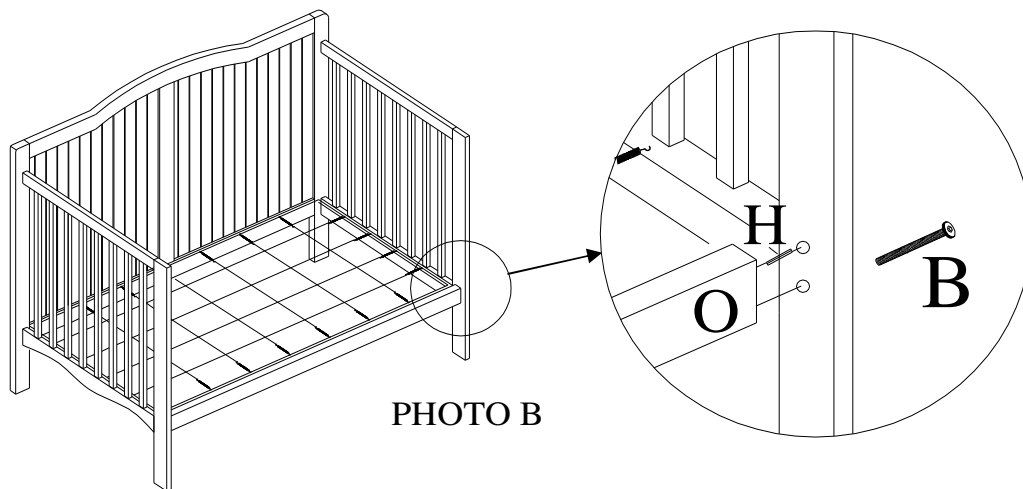

STARTING FROM CRIB:

STEP 1: UNSCREW THE RUBBER WASHER (PART E) FROM THE LOWER DROPSIDE TRACK ON THE LEFT (PART I) AND RIGHT (PART J) FRONT LEGS.

STEP 2: DETACH THE DROPSIDE (PART P) FROM THE LEFT AND RIGHT LEGS BY SLIDING THE UPPER AND LOWER GUIDES ON EACH END OF THE DROPSIDE DOWN UNTIL THEY ARE BELOW THE UPPER AND LOWER DROPSIDE TRACK. ONCE THE DROPSIDE HITS THE FLOOR, THE GUIDES AND TRACKS CAN BE SEPARATED FROM EACH OTHER.

STEP 3: UNSCREW AND DETACH THE LOWER AND UPPER DROPSIDE TRACKS FROM THE LEFT AND RIGHT FRONT LEGS.

STEP 4: IF MATTRESS SUPPORT (PART N) IS NOT IN THE LOWEST POSITION, UNSCREW MATTRESS SUPPORT BOLTS (PART G) FROM FRONT AND BACK LEGS AND MOVE TO THE LOWEST POSITION.

STEP 5: USING THE ALLEN WRENCH PROVIDED, ATTACH THE DAY BED RAIL (PART O) BY USING 2 JOINT CONNECTING BOLTS (PART B) AND 2 GATE PINS (PART H) BETWEEN THE LEFT AND RIGHT LEGS (SEE DETAILS IN PHOTO B).

STEP 6: TIGHTEN ALL SCREWS CLOCKWISE.

STARTING FROM SCRATCH:

STEP 1: FOLLOW STEPS 1 TO 4 OF THE CRIB ASSEMBLY INSTRUCTIONS.

STEP 2: FOLLOW STEPS 3 TO 6 FOR THE DAY BED ASSEMBLY INSTRUCTIONS LOCATED ABOVE (STARTING FROM CRIB).

BED " FULL SIZE"

NOTE: FULL SIZE BED RAILS ARE NOT INCLUDED

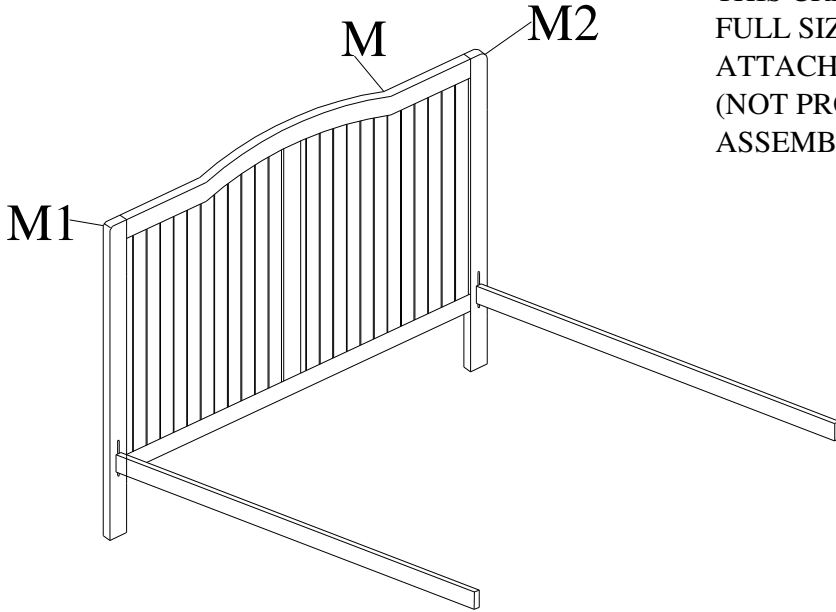

THIS CRIB CAN BE CHANGED TO A FULL SIZE BED.
ATTACH FULL SIZE BED FRAME (NOT PROVIDED) TO HEADBOARD ASSEMBLY AS SHOWN IN DIAGRAM.

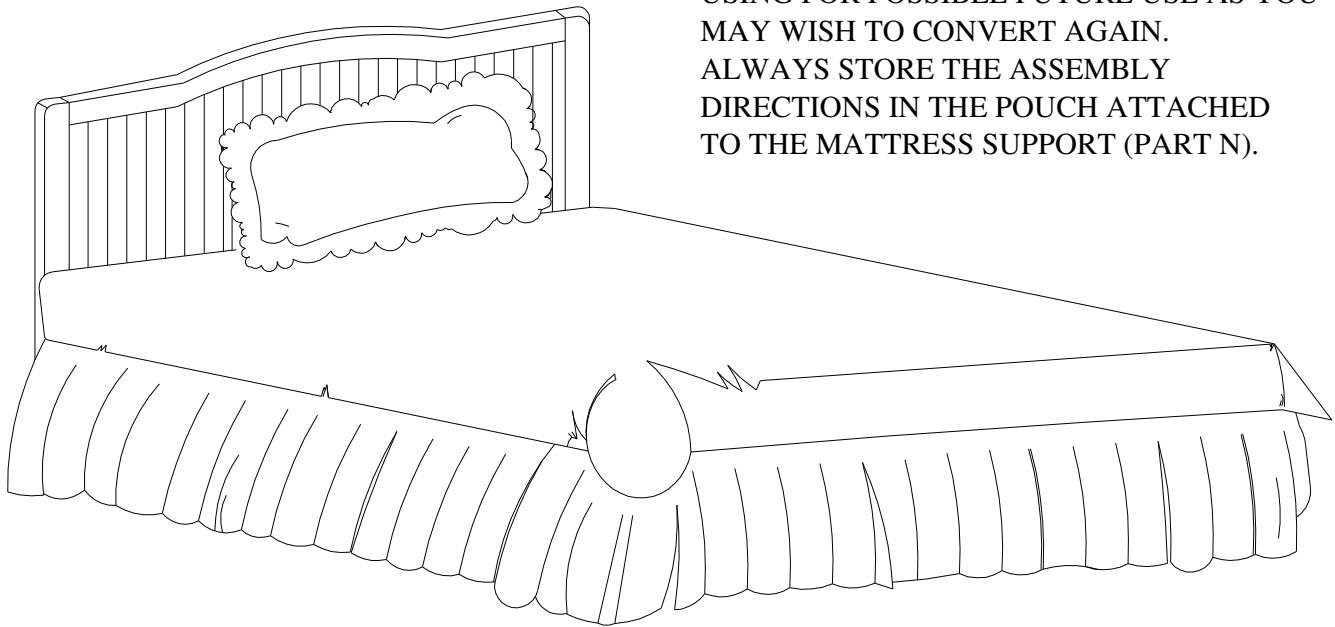

IMPORTANT: STORE AWAY ALL EXTRA PARTS TO THIS "CRIB", "DAY BED" OR "FULL SIZE BED" THAT YOU ARE NOT USING FOR POSSIBLE FUTURE USE AS YOU MAY WISH TO CONVERT AGAIN.
ALWAYS STORE THE ASSEMBLY DIRECTIONS IN THE POUCH ATTACHED TO THE MATTRESS SUPPORT (PART N).